

Stainless Steel Mesh Grill Installation Instructions

For 1990 - 1997 Miatas

1. Remove the tow hooks:

If you have not already done so, remove the two tow hooks on either side of the mouth opening. These hooks were used for chaining down the Miata to a transport vehicle for delivery to the dealership and no longer serve any purpose. Removal requires a 14mm open end wrench and about thirty minutes total. There are three bolts per side. (Note that jacking up the Miata is not necessary; lay on your back under the front end...and bring a flashlight).

2. Install tapered spacers:

Remove the two 10mm bolts found on the top edge of the Miata's mouth. Position the tapered spacers over the holes with tape (see illustration). Note the spacers are positioned at an angle with their bottoms biased toward the center of the grill.

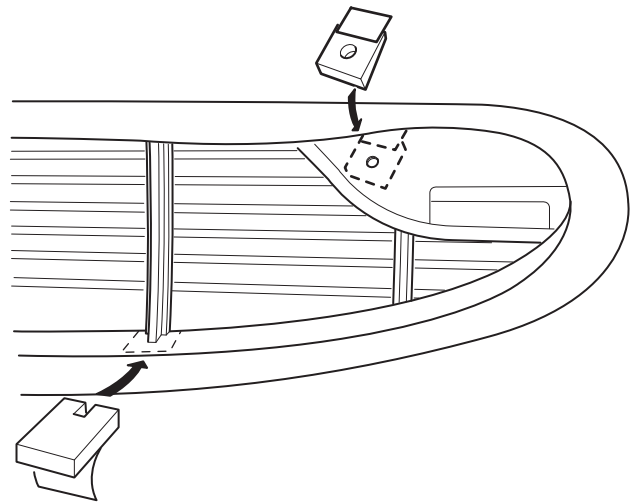
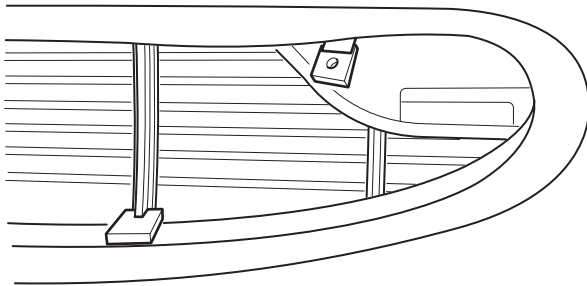

3. Install rectangular spacers:

Clean the plastic at the base of the vertical ribs and install the plastic spacer blocks by peeling the backing paper from the adhesive pad (see illustration).

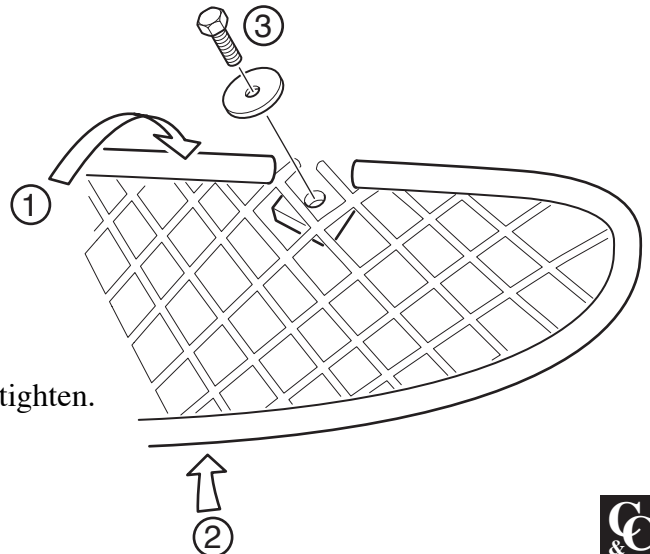

4. Install the grill:

Offer the upper part of the grill up to the tapered spacers and press the lower part of the grill inward until it touches the rectangular spacer blocks. Now fit the supplied bolts and washers (see illustration) and tighten.

Aluminum Lightweight Grille Installation Instructions

For 2004 and newer models MazdaSpeed Turbocharged Miatas

1. Remove the tow hooks:

If you have not already done so, remove the two tow hooks on either side of the mouth opening. These hooks were used for chaining down the Miata to a transport vehicle for delivery to the dealership and no longer serve any purpose. (They should NEVER be used for towing). Removal is accomplished simply by reaching through the mouth of your Miata with a 14mm socket wrench. There are three bolts per hook.

2. Install the Clips: Remove the left and right (but not center) fasteners located directly under the mouth. Jacking the car is not necessary. Lay down to view the underside of the front of the car. The fasteners are black plastic, the size of a dime. With a *very* small screwdriver, pry the small center of one fastener out and remove. The rest of the fastener can now be pulled out. Place one of the L-shaped clips inside the mouth where the fastener goes, and re-insert the fastener from under the mouth. A twisting motion can help the fastener go through the hole in the clip. Still holding the clip down firmly with one hand, secure the assembly by replacing the center of the fastener. Repeat this step for the other side.

3. Install tapered spacers:

Remove the two 10mm bolts found on the top edge of the Miata's mouth. Position the tapered spacers over the holes with tape (see illustration).

Note the spacers are positioned at an angle with their bottoms biased toward the center of the grill.

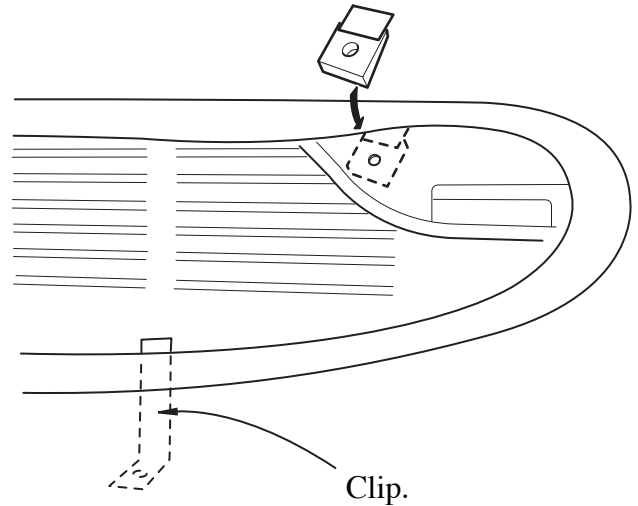
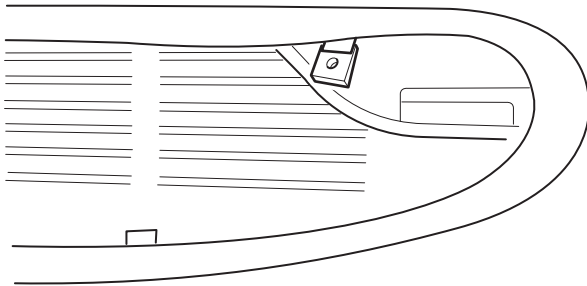

4. Install the Grille:

Offer the upper part of the grille up to the tapered spacers and press the lower part of the grille inward until it touches the clips installed in step 2.

Now fit the supplied bolts and washers (see illustration) and tighten.

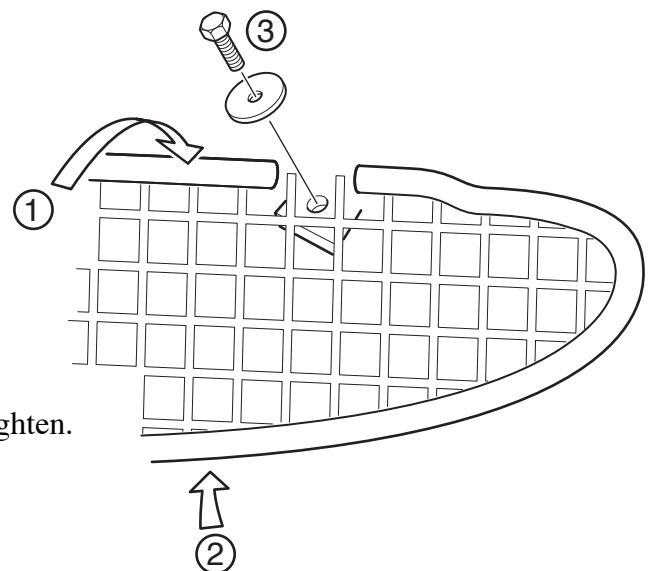

Stainless Steel Mesh Grille Installation Instructions

For 2001 and newer Miatas

1. Remove the tow hooks:

If you have not already done so, remove the two tow hooks on either side of the mouth opening. These hooks were used for chaining down the Miata to a transport vehicle for delivery to the dealership and no longer serve any purpose. Removal requires a metric tool set and about 45 minutes.

A. Jack up the front of the car until the front wheels are left barely touching the ground. (Refer to your manual for safe jacking procedures).

B. Lay down on your back in front of the driver's side wheel and remove the three 8mm hex/phillips bolts at the front lower edge of the wheel splashguard.

C. Now pull back the splashguard, and you have access to remove two of the three 14mm bolts of the driver's side (d/s) tow hook using a socket wrench and extension. Replace the three 8mm bolts.

D. Remove the last 14mm bolt from in front of the Miata (mouth area) using a 3/8 drive ratchet wrench and socket.

E. Place a rag at the edge of the Miata mouth to prevent scratching, and pull the d/s tow hook from the car.

F. Remove the passenger side tow hook in the same fashion, omitting step B.

2. Install tapered spacers:

Remove the two 10mm bolts found on the top edge of the Miata's mouth. Position the tapered spacers over the holes with tape (see illustration).

Note the spacers are positioned at an angle with their bottoms biased toward the center of the grill.

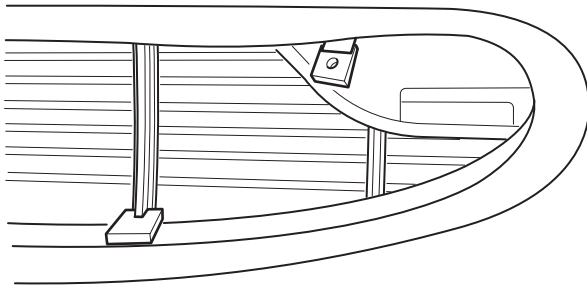
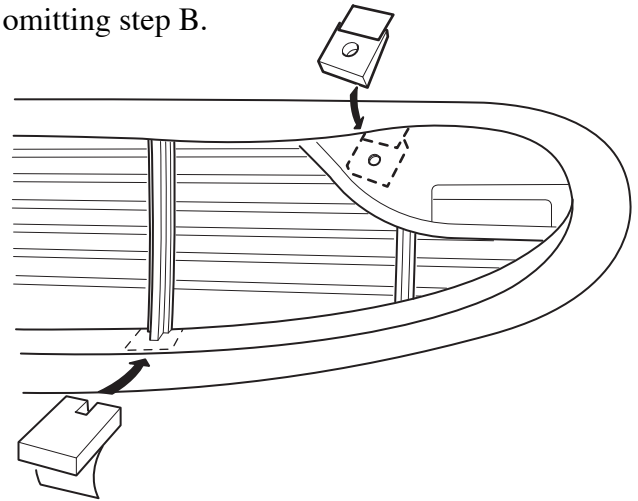

3. Install rectangular spacers:

Clean the plastic at the base of the vertical ribs and install the plastic spacer blocks by peeling the backing from the adhesive pad (see illustration).

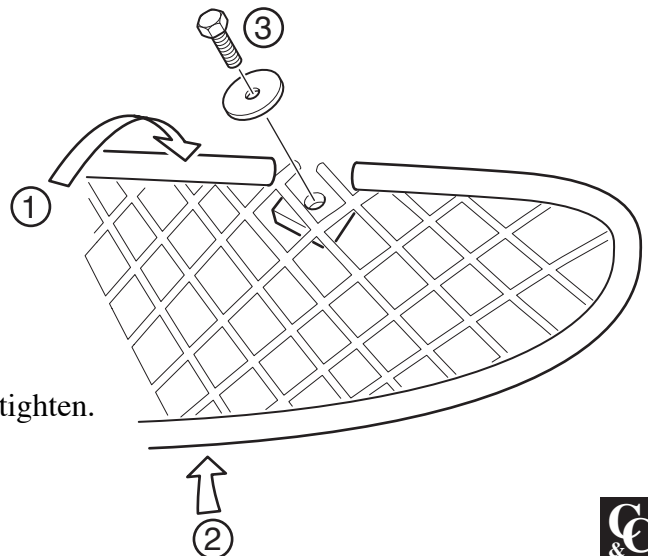

4. Install the Grille:

Offer the upper part of the grille up to the tapered spacers and press the lower part of the grille inward until it touches the rectangular spacer blocks.

Now fit the supplied bolts and washers (see illustration) and tighten.

Stainless Steel Mesh Grille Installation Instructions

For 1999 & 2000 Miatas

1. Remove the tow hooks:

If you have not already done so, remove the two tow hooks on either side of the mouth opening. These hooks were used for chaining down the Miata to a transport vehicle for delivery to the dealership and no longer serve any purpose. Removal requires a 14mm open end wrench and a 14mm socket with extension. There are three bolts per side. Remove the front two using the open-end wrench. Remove the rear bolt by using the socket on a long extension from underneath the car. Removal takes about 45 minutes for both sides. (Note that jacking up the Miata is not necessary; just reach under the front end with one hand and reach into the mouth with the other hand).

2. Install tapered spacers:

Remove the two 10mm bolts found on the top edge of the Miata's mouth. Position the tapered spacers over the holes with tape (see illustration).

Note the spacers are positioned at an angle with their bottoms biased toward the center of the grill.

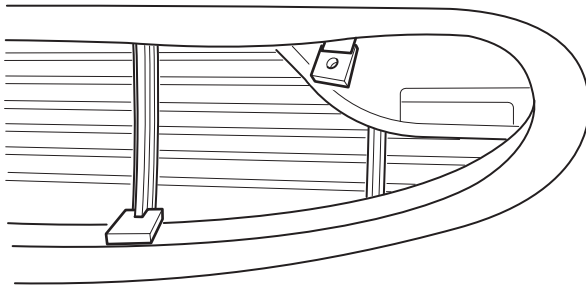
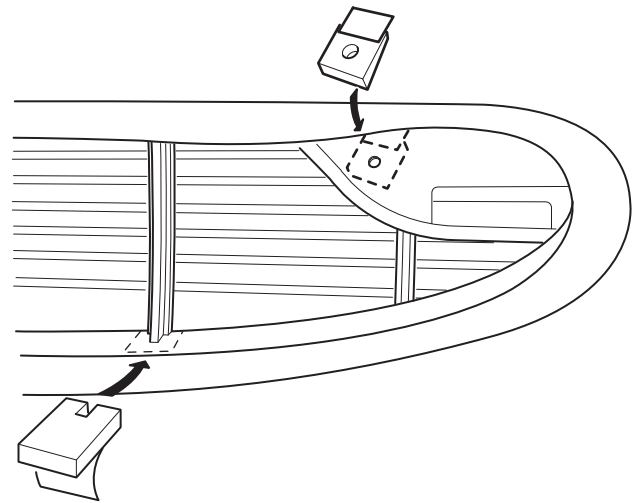

3. Install rectangular spacers:

Clean the plastic at the base of the vertical ribs and install the plastic spacer blocks by peeling the backing from the adhesive pad (see illustration).

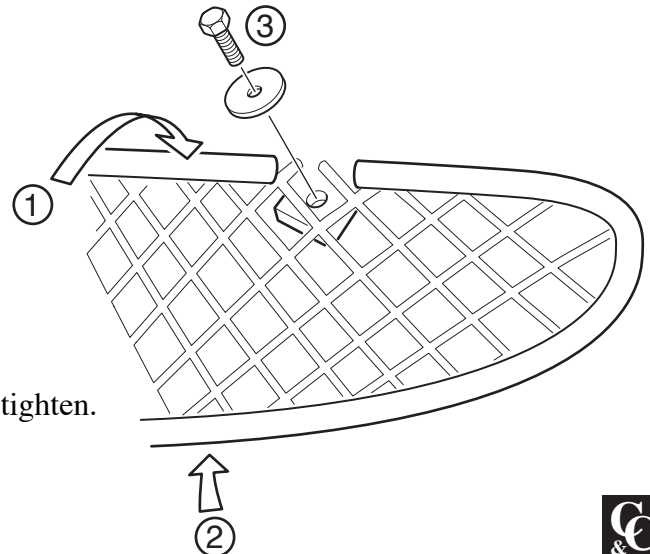

4. Install the Grille:

Offer the upper part of the grille up to the tapered spacers and press the lower part of the grill inward until it touches the rectangular spacer blocks.

Now fit the supplied bolts and washers (see illustration) and tighten.